

Slurry Flanged Knife Gate Valve SKF

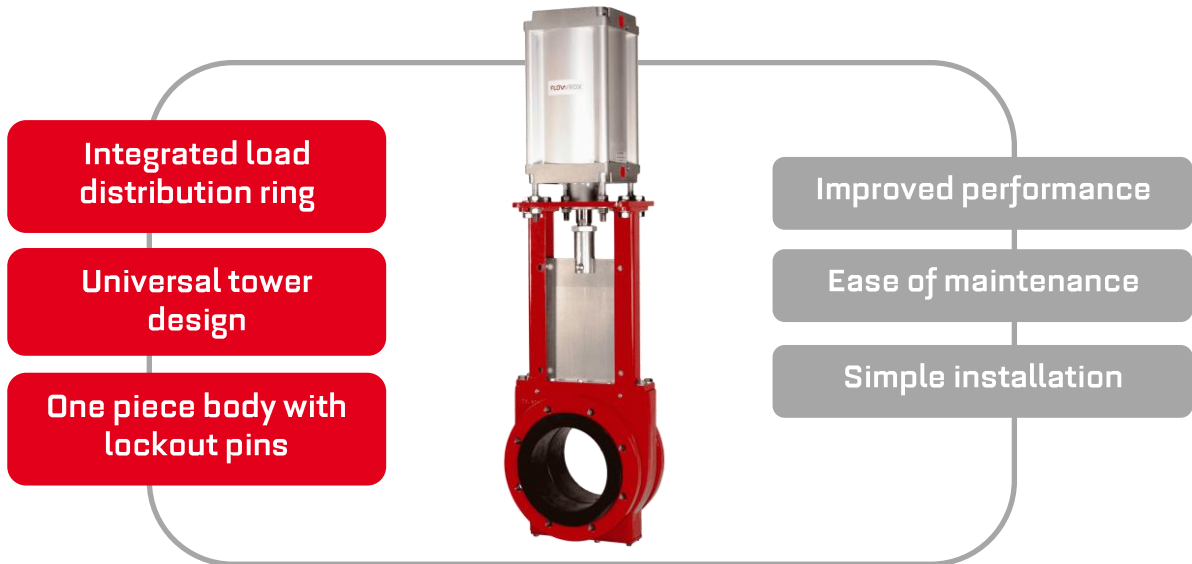

HEAVY DUTY Slurry Knife Gate Valve with flange connections isolates flow in the most demanding process conditions. The complete valve is built around an ease of maintenance concept.

The Flowrox SKF contains only three service parts; ring sleeves, upper seal and the valve gate.

USABILITY BASED ON DESIGN

Flowrox SKF belongs to a new generation knife gate valve series.

The valve designs throughout the series are born from the many years of experience Flowrox has gained, providing solutions for abrasive and corrosive process applications.

Distribute the load – Flowrox SKF features a new load distribution ring that prevents over compression and ensures 100% sealing between the ring sleeve and the valve gate. To add to ease of maintenance, the load ring has been integrated into valve sleeves.

Act freely – The universal tower design of the valve accommodates most actuator types, allowing for actuator interchangeability after valve installation. The tower also ensures that the top plate, body and actuator are always aligned with the pipeline and the gate is in the right position.

Make it simple – The valve body of Flowrox SKF is one piece and takes away the need for sealing between the body halves.

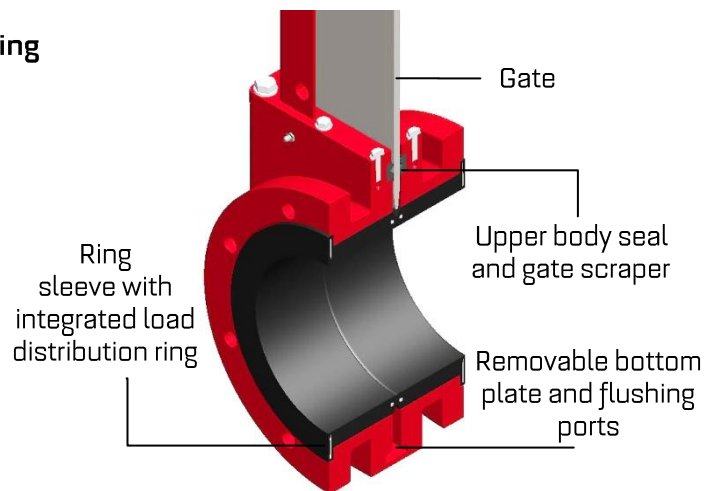

Benefits in the process

- Bi-directional flow tolerates backflow
- Free flow of the process medium
- 100% isolation
- Only the ring sleeves in contact with the process medium
- Integrated load distribution ring
- Integrated upper body seal and gate scraper
- Removable bottom plate accommodates flushing ports
- Face-to-face according to industry standard

PRODUCT SPECIFICATION

Type	Size (DN)	Actuator	Pressure class (PN)	Flange drilling	Body material	Gate material	Ring sleeve material	Auxiliaries
SKF	80 100 150 200 250 300 350 400 450 500 600	M = handwheel MG = manual with gearbox A = pneumatic AU = pneumatic with pneumatic spring H = hydraulic E = electric	10 = 10 bar standard	2 = DIN PN10 3 = DIN PN16 4 = DIN PN25 5 = DIN PN40 6 = ANSI150 7 = ANSI300 9 = other	Ø = Cast iron / Welded steel 2 = AISI 316 4 = other	S = AISI 316 Other on request COATING: Ø = nothing	NR = natural rubber +75°C max NBR = nitrile +100°C max EPDM = ethylene propylene +120°C max	R = readiness for inductive limits R1 = AC/DC R2 = DC, PNP R3 = DC, NPN Z1 = solenoid valve, 24V DC Z2 = solenoid valve, 220V, 50/60 Hz Z3 = solenoid valve, 110V, 50/60 Hz G = guard

Type marking example: SKF100M10-20S0-NR-R1

Standard features

- Gate lock out pins (M, MG & A actuators)
- Bottom plate with flushing ports
- Stem protection (M, MG & E actuators)

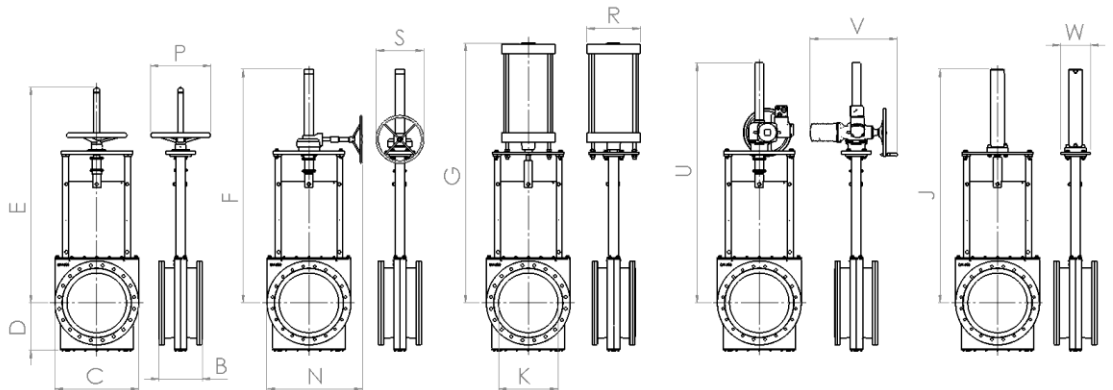

DIMENSIONS AND WEIGHTS

Valve size (DN)	B	B*	C	D	E	F	G	J	U	K	N	P	R	S	V	W	Weight (kg)				
					M	MG	A	H	E		MG	M	A	MG	E	H	M	MG	A	E	H
80	175	179	200	112	628	-	683	-	739	80	-	350	110	-	513	-	32	-	31	57	-
100	175	179	230	132	640	-	725	-	751	100	-	350	120	-	513	-	39	-	41	64	-
150	178	182	285	157	913	-	972	-	879	150	-	350	176	-	513	-	41	-	66	80	-
200	184	188	346	188	1006	-	1115	-	972	200	-	350	220	-	513	-	85	-	100	108	-
250	226	230	410	223	-	-	1316	-	1150	250	-	-	270	-	537	-	-	-	143	142	-
300	257	261	483	262	-	1380	1512	-	1363	300	535	-	340	400	537	-	-	187	253	203	-
350	257	261	533	285	-	1455	1661	1521	1481	350	560	-	340	400	724	200	-	215	282	252	216
400	279	283	600	322	-	1574	1799	1700	1600	400	698	-	340	400	724	200	-	284	349	320	285
450	311	315	645	352	-	1875	2049	1831	1834	450	771	-	450	400	724	250	-	335	420	368	344
500	359	363	705	402	-	1961	2180	1962	2015	500	801	-	450	400	731	250	-	447	527	501	451
600	372	376	825	447	-	2250	-	2291	2234	600	861	-	-	400	795	250	-	629	-	700	652

B* Ring sleeve uncompressed

Dimensions and weights are indicative only – detailed drawings are available on request. All dimensions are in millimeters.

FLOWROX OY

P.O. Box 338, FI-53101 Lappeenranta, Finland
Tel. +358 201 113 311, Fax +358 201 113 300
info@flowrox.com, www.flowrox.com

